

# **Bicycle Owner's Manual**

**E-BIKE**

**X-LAB**

Model: SP5+, ST5+



## **IMPORTANT SAFETY INFORMATION**

**Read this manual carefully before assembling or riding this electric bicycle.  
Improper assembly, use, or maintenance may result in serious injury or death.**

Document Version 1.0  
Publication Date: April 2026  
English – United States

<b>1. USING THIS MANUAL</b>	7
1.1 Important Safety Information	9
1.2 Assembly Guidance and Skill Level	10
1.3 Intended Use and Rider Responsibility	11
Misuse and Modifications	12
1.4 Updates to Information	13
1.5 Questions or Assistance	13
<b>2. BASIC INFORMATION AND SAFETY WARNINGS</b>	14
2.1 General Safety Information	14
2.2 Prohibited Use of Alcohol, Drugs, and Impairing Substances	15
2.3 Age and Rider Capability Requirements	16
2.4 Health and Medical Conditions	17
2.5 Responsibility of Parents and Guardians	18
2.6 Pre-Ride Safety Checklist	19
2.7 Environmental Use Recommendations	21
2.8 Bicycle Size Selection and Fit	22
<b>3. TECHNICAL SPECIFICATIONS</b>	24
	1

3.1 Model Overview	24
3.2 Electrical System Overview	25
3.3 Weight Limits	26
3.4 Environmental Operating Conditions	27
3.5 Serial Number Information	28
3.6 Component Configuration	28
<b>4. ASSEMBLY GUIDE</b>	<b>29</b>
4.1 Before You Begin	30
4.2 Unboxing and Initial Inspection	31
4.3 Assembly Instructions	33
Front Wheel and Fender Installation	33
Stem, Display, and Cable Installation	41
Shifting System Setup	43
Seatpost and Pedal Installation	47
Reflector Installation	51
Final Inspection	53
<b>5. BATTERY CHARGING AND MAINTENANCE</b>	<b>54</b>
	2

5.1 General Battery Safety	54
5.2 Charging the Battery	55
Charging Procedure	56
Charger Indicator Light Description	58
Charging Environment and Temperature	60
5.3 Battery Use During Riding	60
5.4 Storage and Transportation	61
Storage	61
Transportation	61
5.5 Cleaning and Maintenance	61
5.6 Disposal and Recycling	62
5.7 Battery Safety Summary	63
<b>6. OPERATING INSTRUCTIONS</b>	<b>64</b>
6.1 Powering the System On and Off	64
Powering On	64
Powering Off	65
6.2 Pedal-Assist System (PAS)	66

6.3	Selecting Assist Levels	66
6.4	Display Information	67
	Battery Indicator Behavior	70
6.5	Riding Guidelines	71
6.6	Using the Gear Shifting System	71
6.7	Using the Brake System	73
6.8	Automatic System Behavior	75
6.9	After Riding	76
<b>7.</b>	<b>MOBILE APP USAGE</b>	<b>77</b>
7.1	Downloading the Mobile Application	77
7.2	Connecting the App to the Bicycle	78
7.3	App Features	81
7.4	Vehicle Location Tracking (Find My)	83
7.5	E-Bike Class Setting Notice	85
7.6	App Safety Guidance	86
<b>8.</b>	<b>TROUBLESHOOTING</b>	<b>87</b>
8.1	Common Faults and Solutions	87

8.2 Fault Indicator Descriptions	89
8.3 App Self-Diagnostic Function	92
8.4 Mobile App Troubleshooting	93
<b>9. MAINTENANCE</b>	95
9.1 Recommended Service Intervals	95
<b>10. CERTIFICATION AND COMPLIANCE INFORMATION</b>	99
10.1 Federal Communications Commission (FCC) Compliance	99
10.2 Apple Find My Network Compliance	101
10.3 Learn More Instructions	102
10.4 How to Disable	102
<b>11. WARRANTY, SUPPORT, AND CONTACT INFORMATION</b>	103
11.1 Warranty Overview	103
11.2 Warranty Limitations and Exclusions	104
11.3 Customer Support	105
11.4 Service and Repairs	106
11.5 Contact Information	106
11.6 Retention of Documentation	107



## **1. USING THIS MANUAL**

This user manual provides important information about your X-Lab electric bicycle, including product features, safety information, assembly guidance, operating instructions, maintenance recommendations, and troubleshooting tips. It is intended for bicycle owners and riders, not for professional mechanics or service technicians.

### **INSTRUCTIONS PERTAINING TO RISK OF FIRE OR INJURY TO PERSONS**

Read this entire manual carefully before assembling or riding your e-bike for the first time. Understanding the instructions and safety information in this manual is essential for safe operation and helps reduce the risk of accidents, personal injury, or damage to the bicycle.

## IMPORTANT SAFETY INSTRUCTIONS

### **WARNING:**

When using this product, basic precautions should always be followed, including the following:

- a. Read all instructions before using the product.
- b. To reduce the risk of injury, close supervision is necessary when the product is used near children.
- c. Do not put fingers or hands into the product.
- d. Do not use this product if the flexible power cord or output cable is frayed, has broken insulation, or shows any signs of damage.
- e. This equipment is not intended for use at ambient temperatures below 5°F (-15°C) or above 104°F (40°C).
- f. The battery is intended to be charged when the ambient temperature is between 32°F (0°C) and 104°F (40°C). Never charge the battery outside of this temperature range.

## 1.1 Important Safety Information

This manual contains **warnings, cautions, and notices** related to the assembly, operation, charging, maintenance, and storage of your electric bicycle. Failure to follow these instructions may result in serious injury, property damage, or death.

Pay special attention to information identified with the following signal words:

- **WARNING** – Indicates a potentially hazardous situation that could result in serious injury or death if not avoided.
- **CAUTION** – Indicates a potentially hazardous situation that may result in minor or moderate injury, or damage to the bicycle, if not avoided.
- **NOTICE** – Provides important information related to proper operation, maintenance, or longevity of the bicycle.

All safety information in this manual should be reviewed carefully before use.

## 1.2 Assembly Guidance and Skill Level

Correct assembly and adjustment of your electric bicycle are critical to rider safety, performance, and comfort.

**Assembly videos may be provided as supplemental guidance.** These videos are intended to support the written instructions but **do not replace the written assembly steps or safety warnings in this manual.** The written instructions in this manual are the primary reference for safe assembly.

If you do not have prior experience assembling bicycles, or if you are unsure about any step in the assembly process, **X-Lab strongly recommends that assembly and initial inspection be performed by a certified and reputable bicycle technician.**

Improper assembly, adjustment, or modification of the bicycle may result in unsafe riding conditions and could lead to serious injury or damage.

### 1.3 Intended Use and Rider Responsibility

This electric bicycle is designed for general transportation and recreational riding on paved roads and suitable riding surfaces. Riding an electric bicycle involves inherent risks that cannot be eliminated.

Because riding conditions, environments, and rider behavior vary widely, it is not possible to anticipate every situation that may occur during use. As a result, this manual cannot guarantee absolute safety under all conditions. **By choosing to ride this bicycle, the rider assumes responsibility for all risks associated with its use.**

The rider is responsible for:

- Reading and understanding this manual before riding.
- Following all **assembly, operation, and maintenance** instructions.
- Wearing appropriate personal protective equipment.
- Operating the bicycle in a safe and controlled manner.
- Complying with all applicable **federal, state, and local laws and regulations.**
- Inspecting the bicycle before each ride and not riding if any component appears damaged, loose, or unsafe.

**WARNING:** Failure to follow the instructions and warnings in this manual may result in serious injury, property damage, or death.

## Misuse and Modifications

### **NOTICE:**

Do not modify or alter the bicycle, motor system, battery, remote, or electrical components.

Unauthorized modifications, misuse, or operation outside the intended use may:

- Compromise safety
- Void warranty coverage
- Result in non-compliant operation under local regulations

X-Lab is not responsible for damage or injury resulting from improper use or unauthorized modifications.

## **1.4 Updates to Information**

The information contained in this manual is based on the latest product information available at the time of publication. X-Lab reserves the right to update, revise, or discontinue products and documentation at any time without prior notice.

For the most current information, updates, and support resources, please visit the official X-Lab website.

## **1.5 Questions or Assistance**

If you have questions about assembly, operation, maintenance, or safety after reading this manual, please contact X-Lab Customer Support at [support@xds.co](mailto:support@xds.co) before riding the bicycle.

Keep this manual and any other documentation provided with your bicycle for future reference.

## 2. BASIC INFORMATION AND SAFETY WARNINGS

This section contains critical safety information for the operation of your X-Lab electric bicycle.

**Failure to follow these warnings and instructions may result in serious injury, property damage, or death.** Read and understand this entire section before assembling or riding the bicycle.

### 2.1 General Safety Information

Like any form of transportation or physical activity, riding an electric bicycle involves inherent risks. These risks include, but are not limited to, loss of control, collisions, falls, and equipment failure.

By choosing to ride this electric bicycle, you acknowledge and accept these risks and agree to operate the bicycle responsibly, safely, and in accordance with all instructions provided in this manual.

## **2.2 Prohibited Use of Alcohol, Drugs, and Impairing Substances**

**Never operate this electric bicycle under any of the following conditions:**

- While under the influence of alcohol
- While under the influence of drugs (including prescription or over-the-counter medications that may impair alertness or coordination)
- While experiencing physical or mental conditions that impair balance, reaction time, judgment, or safe control of the bicycle

Operating an electric bicycle while impaired significantly increases the risk of accidents, serious injury, or death.

## **2.3 Age and Rider Capability Requirements**

This electric bicycle is intended for use by riders **18 years of age or older.**

The rider must possess the physical ability, coordination, vision, hearing, reaction time, and judgment necessary to:

- Safely control the bicycle
- Respond to unexpected riding conditions
- Comply with applicable traffic laws and regulations

This bicycle **is not intended for use by children.**

## **2.4 Health and Medical Conditions**

Riders with medical or physical conditions that may affect safe operation of the bicycle should consult a qualified medical professional before riding.

This includes, but is not limited to:

- Visual or hearing impairments
- Balance or coordination disorders
- Seizure disorders
- Cardiovascular conditions
- Mobility limitations
- Any condition that could impair safe riding

Failure to consider personal health limitations may increase the risk of serious injury.

## **2.5 Responsibility of Parents and Guardians**

Parents or legal guardians are responsible for ensuring the safety of minors under their supervision. This electric bicycle is **not designed for use by individuals under 18 years of age.**

Do **not** allow children to operate this bicycle.

## 2.6 Pre-Ride Safety Checklist

Before every ride, perform the following checks to ensure the bicycle is in safe operating condition. If any item does not pass inspection, do not ride the bicycle until the issue has been corrected.

### Inspection Item

### Inspection Details

#### Brake System

Confirm that front and rear brakes function properly, ensure brake pads are not excessively worn, verify that brake cables or hoses are undamaged, and confirm proper operation of the brake light.

#### Tires and Wheels

Tire pressure is within the recommended range indicated on the tire sidewall, inspect tires for cracks, bulges, or excessive wear, and ensure wheels spin true without wobble.

#### Steering System

Confirm that the handlebar and stem are securely tightened, and ensure steering rotates smoothly without looseness.

## **Inspection Item**

## **Inspection Details**

### **Battery and Electrical System**

Ensure the battery is sufficiently charged, confirm the charging port is clean and dry, ensure the charging port cover is in place, and verify that the headlight, taillight, and brake light function correctly.

### **Drivetrain System**

Ensure the chain is clean and properly lubricated and confirm smooth and accurate gear shifting.

### **Accessories and Fasteners**

Verify the saddle is properly adjusted and secured, ensure all bolts and fasteners are tightened, and confirm accessories such as racks and fenders are securely installed.

## 2.7 Environmental Use Recommendations

### Wet or Slippery Conditions

If possible, avoid riding in wet weather. If riding in rain is unavoidable, observe the following precautions:

- This bicycle is **not intended for use in heavy rain, standing water, streams, or flooded areas.**
- Never submerge the bicycle or allow it to be immersed in water.
- Water exposure may damage electrical components and increase the risk of malfunction or injury.

**NOTICE:** Riding on wet, muddy, sandy, or loose surfaces may significantly reduce traction and increase stopping distance. Always reduce speed, brake earlier, and avoid sudden or aggressive braking in these conditions. Refer to Section 6 for additional riding and braking guidance.

## **Night Riding**

Avoid riding at night unless absolutely necessary. If night riding is required:

- Ensure the headlight and taillight/brake light are functioning properly.
- Keep all lights turned on at all times.
- Ride at reduced speeds and remain alert to reduced visibility.

## **2.8 Bicycle Size Selection and Fit**

Selecting the correct bicycle size is a critical safety consideration. Riding a bicycle that does not fit properly may affect balance, control, and the rider's ability to stop or maneuver safely.

A key element of proper bicycle fit is standover height. Standover height refers to the distance between the ground and the top tube of the bicycle frame when the rider is standing over the bicycle with both feet flat on the ground.

When standing over the bicycle, there should be a minimum clearance of at least 2 inches (5.08 cm) between the rider's body and the top tube of the frame.

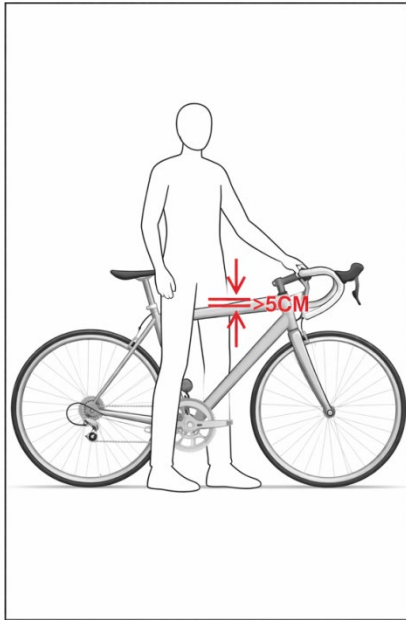

To accurately assess fit, wear the shoes you intend to use while riding.

If the bicycle does not provide sufficient clearance, or if the rider cannot comfortably straddle the frame while maintaining balance, the bicycle may be too large and should not be ridden.

### **WARNING**

Operating a bicycle that is improperly sized may increase the risk of loss of control, falls, or serious injury. If you are unsure whether the bicycle is the correct size, consult a qualified bicycle technician or authorized dealer before riding.

### **3. TECHNICAL SPECIFICATIONS**

This section provides general technical information for your X-Lab electric bicycle. Specifications may vary slightly by model and configuration.

#### **3.1 Model Overview**

This manual applies to the following X-Lab electric bicycle models:

- SP5+
- ST5+

Refer to the product label and serial number to confirm the specific model.

## 3.2 Electrical System Overview

The electric bicycle is equipped with an integrated electrical assist system, which includes:

- Motor
- Battery
- Remote
- Wiring harness
- Display

All electrical components are designed to operate as a system. Use only X-Lab-approved components and accessories.

### 3.3 Weight Limits

To ensure safe operation, **do not exceed the maximum allowable weight limits**, which include the rider and any carried cargo:

<b>Model</b>	<b>Maximum Total Load</b>
SP5+	265 lbs. (120 kg)
ST5+	330 lbs. (150 kg)

**WARNING:** Exceeding the maximum load may affect handling, braking performance, and structural integrity and may result in unsafe riding conditions.

### 3.4 Environmental Operating Conditions

This electric bicycle is designed to operate within the following environmental limits:

<b>Condition</b>	<b>Temperature Range</b>
Operating Temperature	5°F to 104°F (-15°C to 40°C)
Charging Temperature	32°F to 104°F (0°C to 40°C)
Storage Temperature	-4°F to 113°F (-20°C to 45°C)

Operation or storage outside these ranges may result in reduced performance or damage and is not covered under warranty.

### 3.5 Serial Number Information

Each electric bicycle is assigned a unique serial number (SN).

- The serial number is located on the underside of the downtube
- Record the serial number and retain it for future reference

The serial number may be required for warranty service, product support, or theft reporting.

### 3.6 Component Configuration

Component specifications and configurations may vary by model and production batch. X-Lab reserves the right to make changes to components or specifications without prior notice.

**NOTICE:** Specifications provided in this manual are descriptive only and do not constitute a guarantee of performance, range, or suitability for all riding conditions.

Each X-Lab electric bicycle is designed with maximum load limits that must not be exceeded.

- The total load includes the rider, cargo, accessories, and any additional items carried.
- Exceeding recommended limits may reduce braking effectiveness and compromise handling.

## 4. ASSEMBLY GUIDE

This section provides an overview of the assembly process for the X-Lab electric bicycle. Some assembly steps require mechanical knowledge and proper tools.

### **IMPORTANT**

If you do not have prior bicycle assembly experience, it is strongly recommended that assembly be performed by a qualified bicycle technician.

The rider is responsible for ensuring the bicycle is **properly assembled in accordance with this manual before riding.**

**Read this entire section before beginning assembly.** If you are unsure about any step, stop and consult a certified bicycle technician.

Please scan the QR code included on the packaging or in the printed materials provided with the bicycle to view the official assembly video. The video is intended to provide visual guidance and **does not replace the written instructions in this manual.**

## 4.1 Before You Begin

### Required Tools

Before starting assembly, ensure you have the following tools available:

- Metric hex key set (3mm, 4mm, 5mm, 6mm, and T25 Torx)
- 15mm wrench
- **Torque wrench capable of measuring bicycle-specific torque values**
- Bicycle grease

**NOTICE:** Failure to tighten fasteners to the specified torque may result in component damage or unsafe riding conditions.

**Skill Level Advisory:** This bicycle requires proper mechanical assembly. If you do not have prior experience assembling bicycles, **X-Lab strongly recommends that assembly and initial inspection be performed by a certified and reputable bicycle technician.**

## 4.2 Unboxing and Initial Inspection

- 1 Carefully remove the bicycle and all components from the packaging.
- 2 Place the bicycle frame on a stable, flat surface.
- 3 Verify that all components listed below are present and undamaged.

If any components are missing or damaged, **do not proceed with assembly**. Contact X-Lab Customer Support before continuing.

**NOTICE:** Some components shown (rear rack, fenders) are included on **ST5+ models only**.

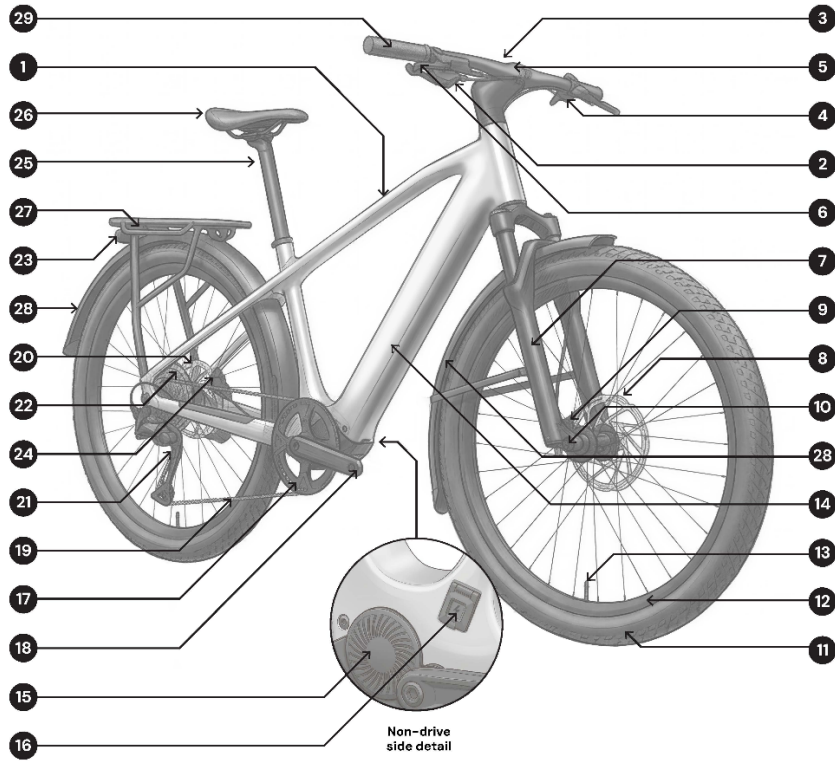

- 1 Frame
- 2 Shifter
- 3 Display screen
- 4 Remote
- 5 Handlebar
- 6 Brake lever
- 7 Front fork
- 8 Front brake disc rotor
- 9 Front brake caliper
- 10 Thru-axle
- 11 Tire
- 12 Rim
- 13 Valve stem
- 14 Battery (Integrated)
- 15 Mid-drive motor
- 16 Charging port
- 17 Chainring
- 18 Crank arm
- 19 Chain
- 20 Rear brake disc rotor
- 21 Rear derailleur
- 22 Cassette
- 23 Taillight
- 24 Rear brake caliper
- 25 Seat post
- 26 Saddle
- 27 Rear rack (ST5+ only)
- 28 Fenders (ST5+ only)
- 29 Grips

### 4.3 Assembly Instructions

If you do not have prior bicycle assembly experience, **assembly by a qualified bicycle technician is strongly recommended**. Improper assembly may result in serious injury or damage to the bicycle.

Follow the steps below **in the order presented**. Do not skip steps.

#### Front Wheel and Fender Installation

##### Step 1 — Prepare the Front Fork

Using a **6 mm hex key**, remove the front fork thru-axle. Remove the plastic fork spacer and the plastic transport spacer located inside the brake caliper.

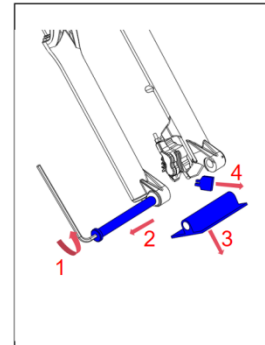

## Step 2 — Install the Brake Disc Rotor

Align the brake disc rotor with the mounting holes on the front hub. **Refer to the marking on the rotor indicating which side is “UP” to ensure proper orientation.**

- 1** Insert all rotor bolts **by hand first** to prevent cross-threading.
- 2** Using a **T25 Torx wrench**, tighten the bolts evenly.

**Tightening torque: 5 Nm**

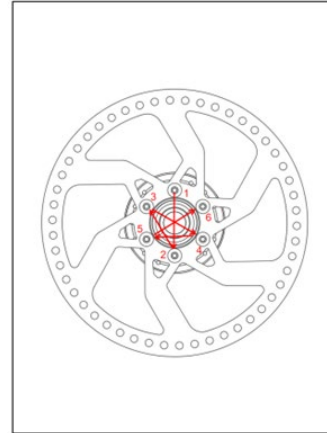

### Step 3 — Position the Front Wheel

Lift the front of the bicycle and guide the front hub into the fork dropouts.

- Ensure the brake disc is positioned **inside the brake caliper**.
- Ensure the axle is fully seated.

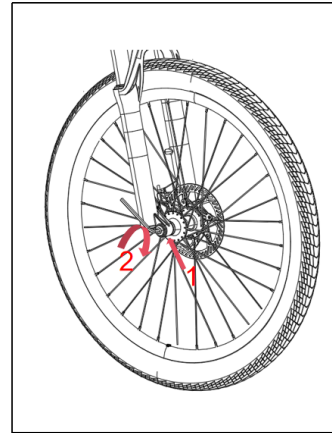

## Step 4 — Install the Thru-Axle

Insert the thru-axle into the opening at the bottom of the front fork.

**1** Turn the axle **clockwise by hand for at least three full turns.**

**2** Using a **6 mm hex key**, tighten the axle securely.

**Tightening torque: Follow the torque specification indicated on the axle.**

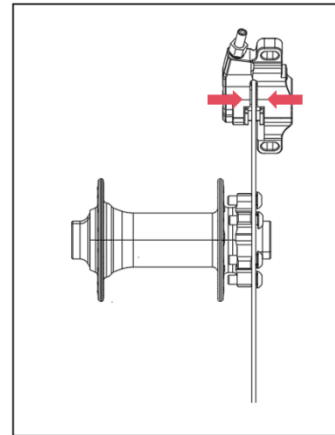

## Step 5 — Check Brake Alignment

- 1 Spin the front wheel and inspect the disc brake system.
  - There must be **no rotor rubbing**.
  - There must be **no abnormal noise**.
- 2 Squeeze the front brake lever to confirm proper brake engagement and lever feel.

If rubbing or noise is present, **do not ride the bicycle**.

**NOTICE:** Front fender components are included on **ST5+ models only**. If your bicycle is an SP5+ model, skip Steps 6 through 9 and proceed to the next assembly section.

## Step 6 — Install the Front Fender Bracket (Model ST5+ ONLY)

- 1 Install the fender mounting bracket onto the front fork crown.
- 2 Using a **5 mm hex key**, tighten the mounting bolts.

**Tightening torque: 5 Nm**

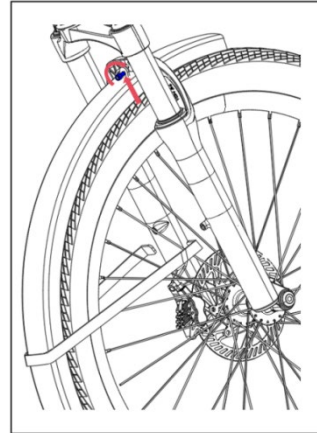

## Step 7 — Install Fender Support Arms (Model ST5+ ONLY)

Align the small mounting hole of the fender support arm with the mounting point on the fork leg.

- 1 Insert and tighten the bolt by hand.
- 2 Repeat on the opposite side.

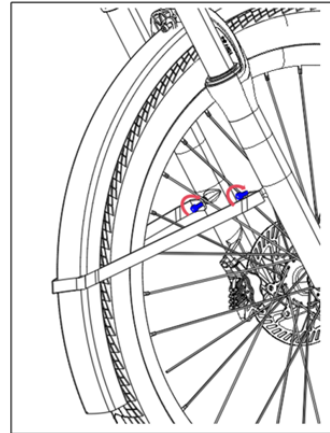

## **Step 8 — Center and Inspect the Fender (Model ST5+ ONLY)**

- 1** Ensure the front fender is centered and that sufficient clearance exists around the wheel.
- 2** If necessary, manually adjust the fender position.
- 3** Ensure no foreign objects or debris are trapped.

## **Step 9 — Secure Fender Support Arms**

Using a **4 mm hex key**, tighten the left and right fender support arms in sequence.

**Tightening torque: 5 Nm**

## Stem, Display, and Cable Installation

### Step 10 — Prepare the Stem and Display

Using a **5 mm hex key**, remove the top cap from the fork steerer tube and remove the cardboard spacer.

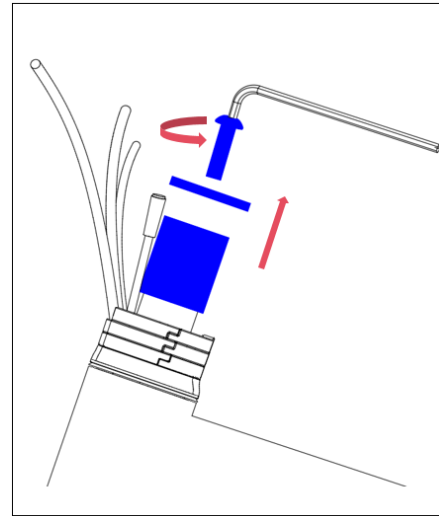

## Step 11 — Install and Align the Handlebar

Install stem onto the fork steerer tube and align the stem parallel with the front wheel.

- 1 Tighten the top cap bolt using a **5 mm hex key**.

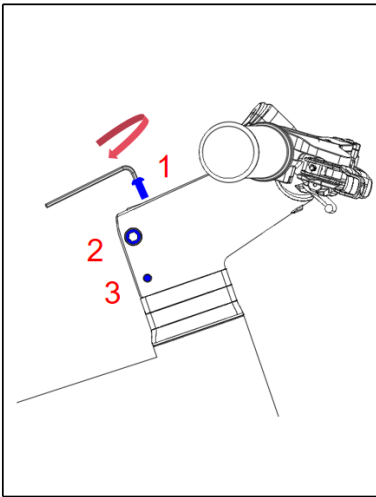

**Tightening torque: 5 Nm**

- 2 Tighten the stem clamp bolts using a **5 mm hex key**.

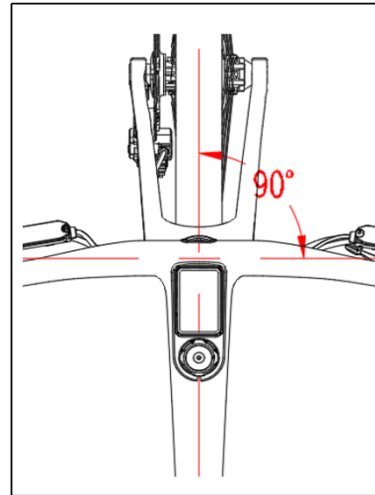

**Tightening torque: 8-10 Nm**

## Shifting System Setup

### Step 12 — Install Right-Side Handlebar Controls

Using a 3 mm hex key, loosen the screw on the **right handlebar grip** and remove the grip from the handlebar.

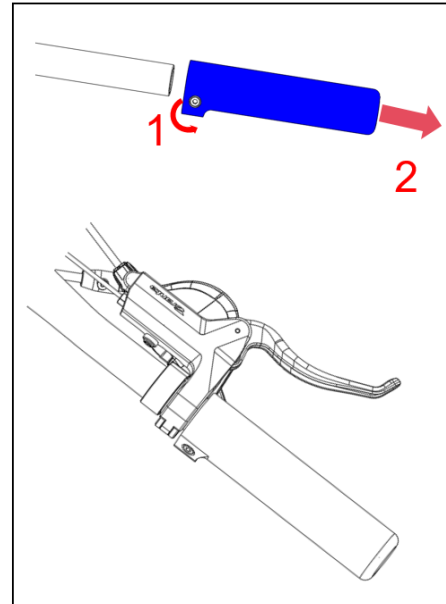

Slide the following components onto the **right side of the handlebar** in this order:

- 1 Right handlebar grip
- 2 Right brake lever
- 3 Right shifter

Reinstall the right handlebar grip and tighten it **clockwise** using a **3 mm hex key**.

**Tightening torque: 2 Nm**

Next, position the right brake lever so it is angled downward at approximately **30–45 degrees from horizontal**. Tighten the brake lever clamp screw using a 4 mm hex key.

**Tightening torque: 5 Nm**

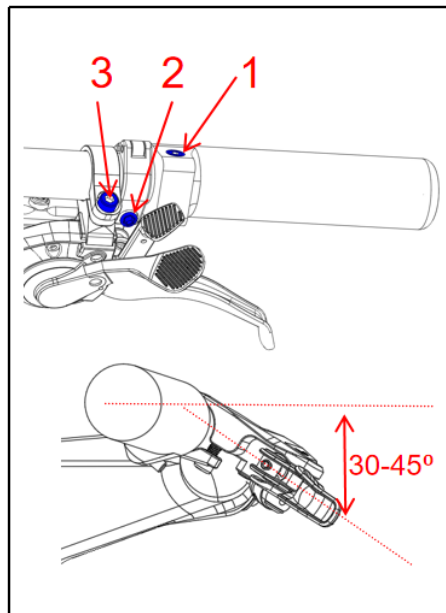

Align the right shifter so it sits comfortably against the brake lever and tighten the shifter clamp screw using a 5 mm hex key.

**Tightening torque: 3-5 Nm**

**NOTICE:** Ensure the right handlebar grip is installed at the same angle and position as the left handlebar grip to maintain proper hand alignment and control.

## Step 13 — Connect Handlebar Electrical Connector

- 1 Locate the **electrical connector** at the front of the bicycle frame and the corresponding **electrical connector** on the **left side of the handlebar**.
- 2 Align the connectors according to the **orientation markings** shown in the diagram. Press the connectors firmly together until they are fully seated and securely connected.
- 3 Once connected, carefully **insert the joined connector into the handlebar**, ensuring the cable is not twisted, pinched, or under tension.

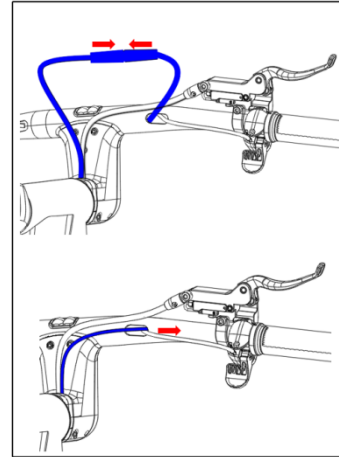

**NOTICE:** The electrical connector must be inserted in the correct orientation. Do not force the connector into place. Improper connection may result in system malfunction or damage to electrical components.

## Step 14 — Install QUAD LOCK Phone Mount

- 1 Remove the protective paper from the QUAD LOCK phone mount.
- 2 Using a **3 mm hex key**, secure the mounting bolt to the top of the stem cap.

**Tightening torque: 2.5 Nm**

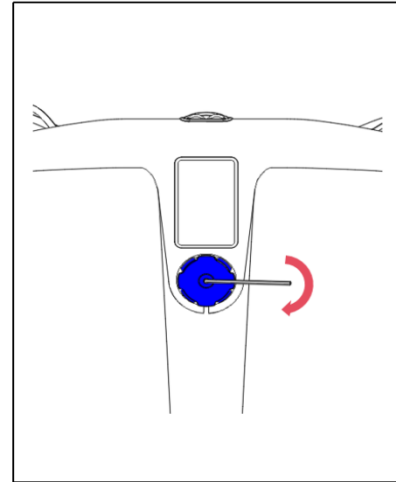

## Seatpost and Pedal Installation

### Step 15 — Seatpost Installation and Adjustment

- 1 Insert the seatpost into the seat tube and adjust the height.

2 Using a 4 mm hex key, tighten the seatpost clamp bolt.

**Tightening torque: 6 Nm**

**WARNING: The seatpost must be inserted beyond the “MIN INSERT” mark. Failure to do so may result in serious injury or frame damage.**

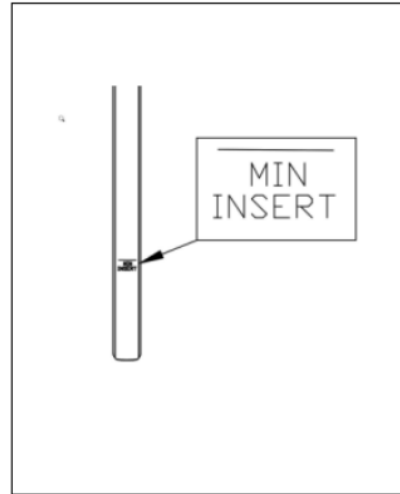
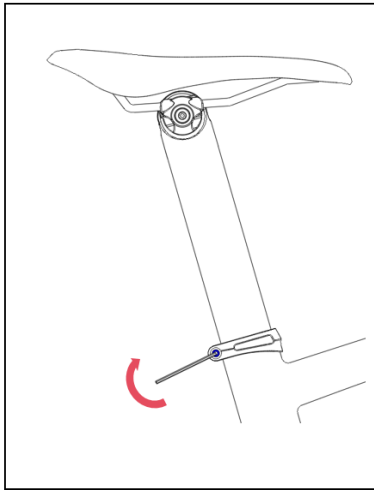

## Step 16 — Pedal Identification and Preparation

1 Identify the pedals by axle markings:

“L” — Left pedal

“R” — Right pedal

2 Apply a small amount of grease to the threads of each pedal.

## Step 17 — Left Pedal Installation

1 Thread the left pedal into the crank arm **counterclockwise by hand**.

2 Using a **15 mm open-end wrench**, fully tighten the pedal.

**Tightening torque: 40 Nm**

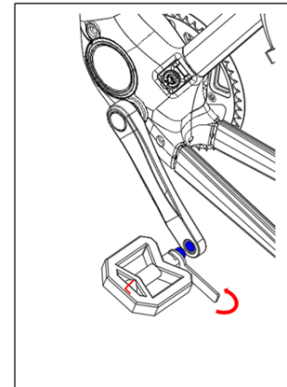

## Step 18 — Right Pedal Installation

- 1 Thread the right pedal into the crank arm **clockwise by hand**.
- 2 Using a **15 mm open-end wrench**, fully tighten the pedal.

**Tightening torque: 40 Nm**

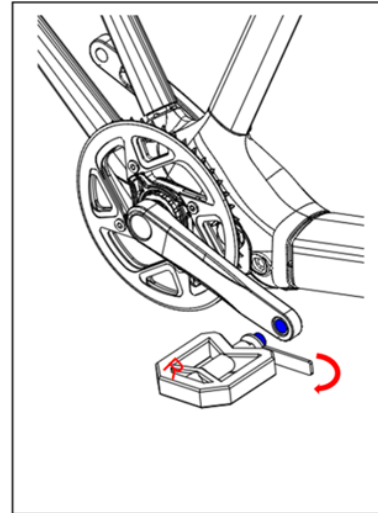

## Reflector Installation

### Step 19 — Install Front and Rear Reflectors

- 1 Using a **Phillips screwdriver**, remove the clamp screws from the **rear reflector bracket** (red reflector).
- 2 Position the rear reflector clamp around the **seatpost** and reinstall the clamp screws. Adjust the reflector so it faces **directly rearward**, then tighten the screws securely. The reflector angle may be fine-tuned using the adjustment screw on the bracket.

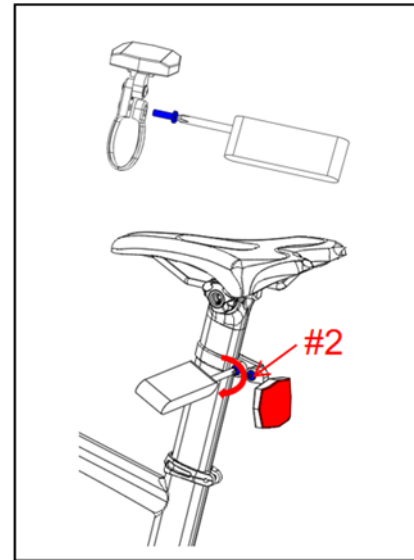

- 3 Next, remove the clamp screw from the **front reflector bracket** (white reflector). Position the clamp around the handlebar, adjust the reflector so it faces **directly forward**, and tighten the clamp screw securely. The reflector angle may be adjusted using the adjustment screw on the bracket.

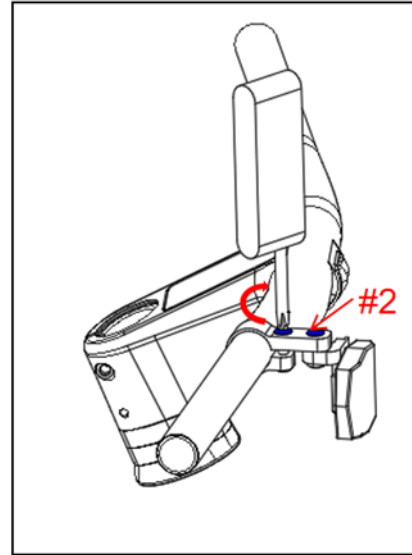

**NOTICE:** Reflectors must be securely mounted and properly oriented to ensure visibility and compliance with local regulations. Do not ride the bicycle if reflectors are loose, damaged, or incorrectly positioned.

## Final Inspection

### Step 20 — Final Assembly Inspection

Before riding, verify the following:

- Tire pressure is within the recommended range. Refer to the tire sidewall for recommended pressure.
- Handlebar turns smoothly
- No brake rotor rubbing or abnormal noise
- Brake lever operation is responsive
- Brake light functions correctly
- Gear shifting operates smoothly
- All required reflectors are installed in accordance with local regulations.

If any issue is identified, **do not ride the bicycle** until it has been corrected.

## 5. BATTERY CHARGING AND MAINTENANCE

This section provides important information about safe use, charging, storage, and care of the lithium-ion battery used in your X-Lab electric bicycle. **Failure to follow these instructions may result in fire, electric shock, serious injury, or damage to the battery or bicycle.**

Read this entire section before charging or operating the bicycle.

### 5.1 General Battery Safety

The battery is a critical component of the electric bicycle. Improper use, charging, storage, or handling of the battery may create hazardous conditions.

#### **WARNING:**

- Use **only X-Lab-approved batteries and chargers (Charger model LBC046M101203)**.
- Do not disassemble, modify, puncture, crush, or expose the battery to impact.
- Do not expose the battery to fire, extreme heat, or direct sunlight for extended periods.
- Keep the battery away from water and moisture.

If the battery is damaged, dropped, emits odor, becomes excessively hot, leaks fluid, or shows signs of swelling, **stop using it immediately** and contact X-Lab Customer Support.

## 5.2 Charging the Battery

- Charge the battery **indoors**, in a dry, well-ventilated area
- Place the battery on a **non-flammable surface** while charging.
- Keep the charging area free of combustible materials.
- Do not charge the battery near flammable liquids or gases.

## Charging Procedure

- 1 Ensure the charger is unplugged from the wall outlet.
- 2 Connect the charger (B) to the battery charging port (A).
- 3 Plug the charger into a grounded wall outlet.
- 4 Allow the battery to charge until charging is complete.
- 5 Unplug the charger from the wall outlet before disconnecting it from the battery.



### **WARNING:**

- Do not leave the battery charging unattended for extended periods.
- Do not cover the battery or charger during charging



## Charger Indicator Light Description

The battery charger is equipped with indicator lights that display the current charging status.

<b>Indicator Light</b>	<b>Status</b>	<b>Action / Solution</b>
Solid Red	Charging in progress	—
Solid Green	Fully charged	Disconnect the charger.
Flashing Green	No communication / communication failure	Unplug and reconnect the charger at the bicycle charging port.
Red and Green flashing alternately	Charging temperature out of range or other protection triggered	Error. See <b>Charging Errors.</b>

## Charging Errors

If the charger indicator lights display an abnormal condition or charging does not proceed normally:

- Check the ambient temperature and ensure it remains between **32°F–104°F (0°C and 40°C)**.
- Unplug and reconnect the charger at the bicycle charging port to ensure proper connection.
- If charging still cannot proceed normally, **replace the charger or contact X-Lab Customer Support regarding the battery.**

### **WARNING**

Do not continue charging if abnormal conditions persist. Continued charging under fault conditions may increase the risk of fire, electric shock, or battery damage.

## Charging Environment and Temperature

Charging or storing the battery outside recommended temperature ranges may reduce performance or cause damage.

- Do not charge the battery in extreme heat or cold.
- If the battery has been exposed to cold temperatures, allow it to reach room temperature before charging.

If the battery becomes excessively hot during charging, **disconnect the charger immediately** and allow the battery to cool.

### 5.3 Battery Use During Riding

- The battery supplies power only when the system is powered on.
- Riding range and performance vary based on terrain, assist level, rider weight, and environmental conditions.
- Reduced performance may occur in cold weather.

**NOTICE:** There are no user-serviceable parts inside the battery. Do not attempt to open or service it.

## **5.4 Storage and Transportation**

### **Storage**

If the bicycle will not be used for an extended period:

- Avoid direct sunlight and high temperatures.
- Periodically check the battery charge level.

### **Transportation**

- Secure the battery to prevent movement or impact.
- Follow all applicable regulations when transporting lithium-ion batteries.

## **5.5 Cleaning and Maintenance**

- Clean the battery exterior with a dry or slightly damp cloth.
- Do not use high-pressure water, solvents, or abrasive cleaners.

Ensure the battery contacts and charging port are clean and dry before charging or reinstalling.

## **5.6 Disposal and Recycling**

Lithium-ion batteries must be disposed of or recycled properly.

**Do not dispose of the battery in household trash.**

Follow local regulations for battery recycling and disposal or contact X-Lab Customer Support for assistance.

## 5.7 Battery Safety Summary

### For safe operation:

- Use only X-Lab-approved batteries and chargers.
- Follow all charging, storage, and handling instructions.
- Do not modify or disassemble the battery.
- Stop use immediately if the battery shows signs of damage.

Failure to follow these instructions may result in serious injury or property damage.

## 6. OPERATING INSTRUCTIONS

This section explains how to power on the electric bicycle, use the pedal-assist system, and understand basic display functions. **Read and understand this section before riding.**

Always operate the bicycle in accordance with local laws and regulations.

### 6.1 Powering the System On and Off

#### Powering On

- Press and hold the **power button** on the display until the display turns on.



## Powering Off

- Press and hold the **power button** until the display turns off, **or**
- The system may power off automatically after a period of inactivity.

**NOTICE:** Always power off the bicycle before performing adjustments or transporting the bicycle.

## 6.2 Pedal-Assist System (PAS)

The electric bicycle is equipped with a pedal-assist system that provides motor assistance while pedaling or when utilizing the throttle lever on the handlebar-mounted remote.

- Assistance level is controlled using the buttons on the remote.
- Higher assist levels provide more motor support and reduce battery range.

### **WARNING**

Sudden changes in assist level may affect bicycle handling. Always select an assist level appropriate for riding conditions.

## 6.3 Selecting Assist Levels

Use the “+” and “-” buttons on the display to adjust the assist level.

- 1 Press “+” to increase assistance.
- 2 Press “-” to decrease assistance.

The selected assist level will be shown on the display.

**NOTICE:** Start riding in a lower assist level and increase gradually as needed.

## 6.4 Display Information

The display provides real-time riding and system information. **Do not** attempt to adjust display settings while riding.

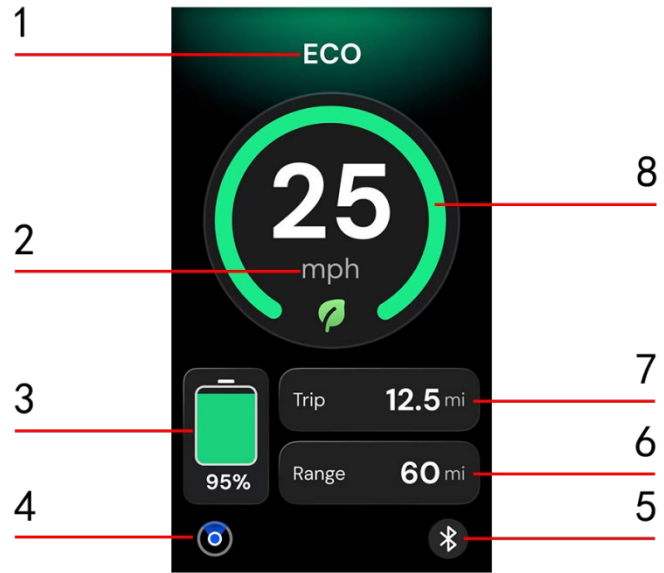

No.	Display Item	Description
1	Riding Mode Indicator	Displays the currently selected riding mode: <b>OFF, ECO, SPORT, or TURBO</b> . Riding mode affects the level of motor assistance and battery consumption.
2	Speed Unit	Displays the current speed unit. After connecting to the X-Lab Bikes app, the speed unit can be changed to metric units via the Vehicle Settings page in the app.
3	Battery Level Indicator	Displays remaining battery charge using a bar indicator and percentage. Color and behavior change as battery level decreases.
4	Error Indicator/ Find My Status Icon	<p>Indicates an error related to a specific e-bike system component. Refer to <b>Section 8.2 – Fault Indicator Descriptions</b> for definitions of the error symbols.</p> <p>Indicates the connection status of the Find My function. Icon status reflects whether the feature is enabled and paired with a mobile device.</p> <p>(If both Find My and the Error Indicator are active at the same time, only the Error Indicator will be displayed.)</p>

<b>No.</b>	<b>Display Item</b>	<b>Description</b>
<b>5</b>	Bluetooth Connection Icon	Indicates the current Bluetooth connection status between the bicycle and the X-Lab Bikes app. The icon turns gray if the connection is lost.
<b>6</b>	Trip Distance	Displays the distance traveled during the current ride. Measurement begins automatically when the bicycle is powered on.
<b>7</b>	Remaining Range	Displays an estimated remaining riding distance based on current battery level and riding conditions. This value is for reference only.
<b>8</b>	Speed Dial	Displays the bicycle's real-time speed. The arc of the speed dial changes dynamically according to speed. Speed limit settings compliant with local regulations may be adjusted through the mobile application.

## Battery Indicator Behavior

<b>Battery Level</b>	<b>Indicator Behavior</b>
<b>100% – 20%</b>	Battery bar appears green
<b>20% – 10%</b>	Battery bar turns yellow and motor output may be reduced
<b>10% or below</b>	Battery bar turns red
<b>3% or below</b>	Battery bar flashes and motor assistance stops
<b>0%</b>	Bicycle powers off automatically

** IMPORTANT**

**Failure to recharge the battery in a timely manner may result in long-term over-discharge. Battery damage caused by extended over-discharge (greater than two months) is considered user-related and is not covered under warranty.**

## 6.5 Riding Guidelines

- Always start riding at a low speed.
- Keep both hands on the handlebars.
- Be prepared for increased acceleration when assist is active.
- Reduce the assist level when riding in crowded, slippery, unfamiliar, or low-visibility conditions.

### **WARNING**

Electric bicycles accelerate faster than traditional bicycles. Failure to control speed may result in loss of control or injury.

## 6.6 Using the Gear Shifting System

The rear derailleur is controlled by the **shift lever located on the right side of the handlebar**. Shifting gears moves the chain between different cogs on the rear cassette, allowing you to adjust pedaling effort and riding speed.

- **Smaller cogs** provide higher gear ratios, requiring more pedaling effort but allowing the bicycle to travel farther with each pedal rotation.

- **Larger cogs** provide lower gear ratios, requiring less pedaling effort but covering less distance per pedal rotation.

Moving the chain from a smaller cog to a larger cog is called **downshifting**. Moving the chain from a larger cog to a smaller cog is called **upshifting**.

Always shift gears **while pedaling forward**. The derailleur system is designed to shift only when the chain is moving.

For safer riding:

- Downshift into a **larger cog before coming to a stop** to allow easier and more controlled acceleration when starting again.
- Downshift into a **larger cog before riding uphill** to reduce strain on the drivetrain and rider.

If gear changes are not smooth or the chain hesitates during shifting, the derailleur may require adjustment. **Do not continue riding if shifting is unreliable**. Have the bicycle inspected and adjusted by a qualified bicycle technician.

## 6.7 Using the Brake System

Understanding how your brake system operates is essential for safe riding.

On this bicycle:

- The **right brake lever** controls the **rear brake**
- The **left brake lever** controls the **front brake**

Before riding, ensure your hands can comfortably reach and fully operate both brake levers. If the levers are difficult to reach or operate, consult a qualified bicycle technician for adjustment.

### Braking Technique

Bicycle brakes slow the bicycle by creating friction at the brake discs. To maintain proper braking performance:

- Keep brake discs and calipers clean and free of dirt, oil, grease, or other contaminants.
- Always brake progressively, gradually increasing brake force rather than applying sudden, full pressure.
- The brake levers have integrated switches that cut off all motor assistance when force is applied to the brake lever.

Avoid locking the wheels. Locked wheels reduce braking effectiveness and eliminate steering control. If a wheel begins to lock, **release the brake slightly** to allow the wheel to rotate.

When braking:

- Your body naturally shifts forward due to inertia.
- Apply **balanced braking**, increasing front brake pressure gradually while reducing rear brake pressure as needed.
- Use extra caution when braking downhill, as weight transfer is greater.

## 6.8 Riding on Wet or Soft Surfaces

Wet, muddy, or loose surfaces reduce traction and increase stopping distance.

- Brake earlier and more gently.
- Reduce speed and allow additional distance for stopping.
- Be prepared for reduced braking performance.

### **WARNING**

Sudden or excessive braking may cause loss of control, especially on wet, loose, or downhill surfaces.

## 6.8 Automatic System Behavior

The motor system may reduce or stop assistance under certain conditions, including but not limited to:

- Low battery charge
- System protection activation
- Overheating protection

If motor assistance stops unexpectedly, **reduce speed and stop riding safely**. Check the display for status information.

## 6.9 After Riding

After each ride:

- Power off the system.
- Inspect the bicycle for visible damage.
- Recharge the battery as needed.

Instructions regarding battery charging, temperature limits for equipment use and storage, battery use and storage, and the recommended temperature range for charging are provided in **Technical Specifications**.

A warning against modifying or attempting to repair the e-bike system, except as indicated in the instructions for use and care, is provided in **Misuse and Modifications**.

Charging of the e-bike must only be performed using the manufacturer's recommended charger. Refer to **Battery Charging and Maintenance** for details.

## 7. MOBILE APP USAGE

Some models may support connection to a mobile application for viewing ride information and adjusting certain non-safety-critical settings.

**NOTICE:** Use of the mobile application is **optional**. The electric bicycle can be operated safely without the application.

### 7.1 Downloading the Mobile Application

The mobile application can be downloaded to a compatible smartphone.

- 1 Open the Apple App Store or Google Play Store on your mobile device.
- 2 Search for the “**X-Lab Bikes**” mobile application.
- 3 Download and install the application by following the on-screen instructions.

Application availability and compatibility may vary by device, operating system, or region.

## 7.2 Connecting the App to the Bicycle

- 1 Ensure the bicycle is powered on.
- 2 Enable Bluetooth on your mobile device.
- 3 Launch the X-Lab Bikes app.
- 4 Follow the pairing instructions provided within the mobile application.

**NOTICE:** Please ensure the phone is close to the device and connected to WiFi or cellular data.

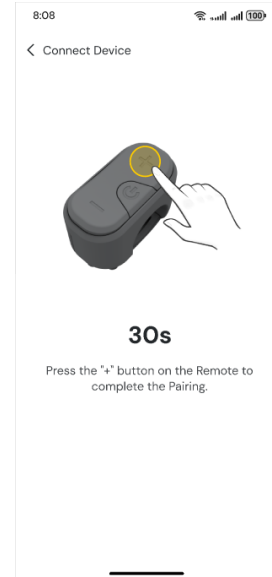
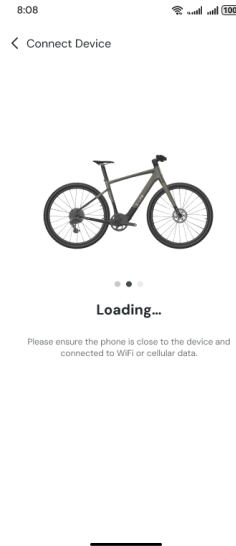
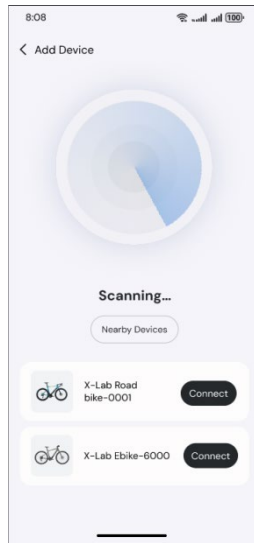
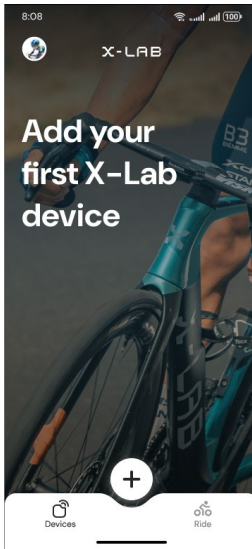

If pairing is unsuccessful, restart the application and repeat the process.

Loss of app connection does not affect basic bicycle operation using the display and remote

**NOTICE:** If you have multiple X-Lab electric bicycles paired with the mobile application, you can manage them by switching between device cards on the app's home screen. The mobile application can connect to **only one Bluetooth device at a time.**

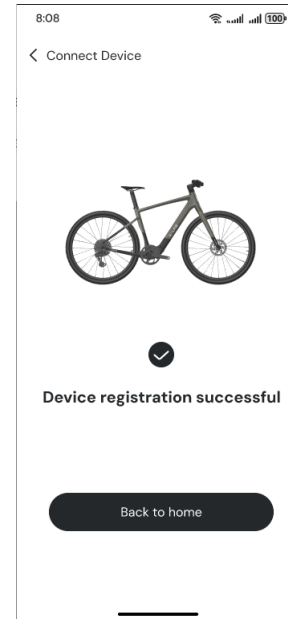

### 7.3 App Features

After a successful connection between the electric bicycle and the mobile application, the following features may be available. Feature availability may vary by model, region, device type, and software version.

**NOTICE:** Use of the mobile application is optional. The electric bicycle can be operated safely without the application.

<b>Feature</b>	<b>Description</b>
<b>Battery Status Monitoring</b>	Displays real-time battery charge percentage and an estimated remaining riding range. Range estimates are for reference only and may vary based on riding conditions.
<b>Vehicle Information</b>	Provides access to vehicle details such as the serial number (SN), firmware version, and total accumulated mileage.
<b>Ride Records</b>	Automatically records ride data, including ride duration, distance traveled, and speed information.
<b>Personalized Settings</b>	Allows adjustment of selected user preferences, such as display brightness, measurement units, and other customizable parameters.
<b>Vehicle Location (Find My)</b>	Allows the bicycle to be located using the Apple <b>Find My</b> network when properly enabled and paired.
<b>Ride History and Route Maps</b>	Displays historical ride data, including past routes and summarized riding statistics.
<b>E-Bike Class Settings</b>	Allows the rider to view and modify the e-bike class setting through the mobile application. The bicycle ships configured as Class 2.

## 7.4 Vehicle Location Tracking (Find My)

This feature is available on **iOS devices only**. To use it, the rider must enable **Find My** on their Apple device and complete the pairing process within the mobile application.

**NOTICE:** Location tracking functionality depends on Apple Find My network availability and device settings. Availability and performance may vary by region.

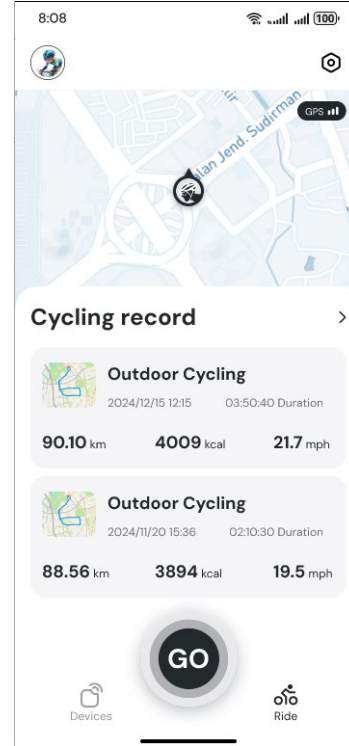
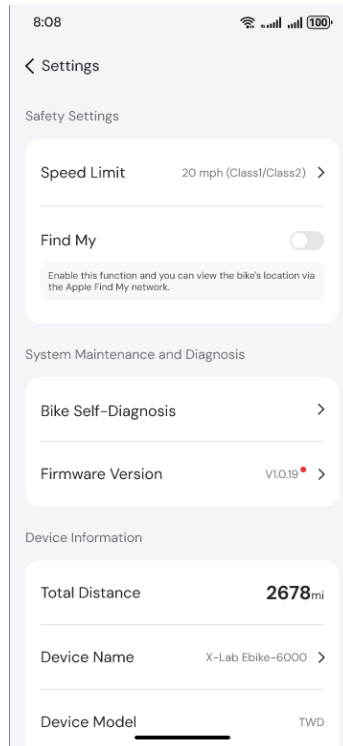
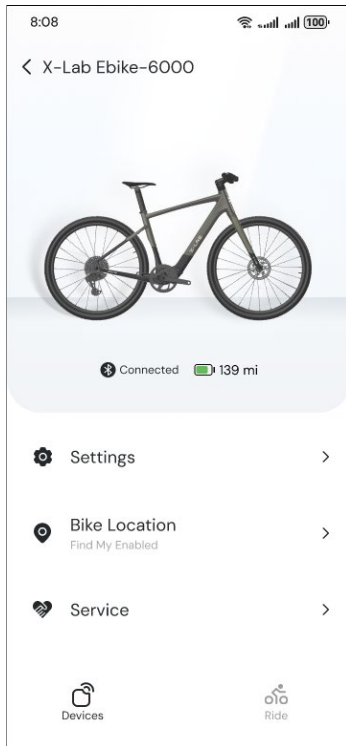

## 7.5 E-Bike Class Setting Notice

**NOTICE:** The electric bicycle ships configured as **Class 2** (up to 20 mph throttle assistance and 20 mph pedal assistance).

The rider may view and modify the class setting within the mobile application. Available configurations may include:

- **Class 3 (California)** – up to 28 mph pedal assistance
- **Class 3 (New York City)** – up to 25 mph pedal assistance and 20 mph throttle assistance
- **Class 3 (Rest of U.S.)** – up to 28 mph pedal assistance and 20 mph throttle assistance

The rider is responsible for selecting a class setting that complies with **applicable federal, state, and local laws and regulations**. Laws governing electric bicycle classification and permitted use vary by jurisdiction.

Changing the class setting may affect where and how the bicycle may be legally operated.

## 7.6 App Safety Guidance

### **NOTICE:**

- Do not use the mobile application while riding.
- Stop the bicycle before interacting with the app.
- The mobile application does not replace safe riding practices or the instructions in this manual.

If the app connection is lost, the bicycle will continue to operate normally using the display and control buttons on the remote.

## 8. TROUBLESHOOTING

This section provides general guidance for identifying common issues. If an issue cannot be resolved using the information below, **stop using the bicycle and contact X-Lab Customer Support or a qualified bicycle technician.**



Always power off the bicycle before inspecting any components unless otherwise noted.

### 8.1 Common Faults and Solutions

Symptom	Possible Cause	Solution
<b>The e-bike will not power on</b>	Low battery level; brake lever engaged	Recharge the battery; release the brake lever
<b>Poor acceleration or reduced speed</b>	Low battery level; throttle malfunction	Recharge or replace the battery; replace the throttle assembly

<b>Motor does not respond</b>	Loose wiring; throttle malfunction; motor power issue	Check and secure wiring; replace throttle; inspect battery
<b>Reduced riding range</b>	Low tire pressure; low battery level; heavy load; brake drag	Adjust tire pressure; recharge or replace battery; reduce load; adjust brakes
<b>Battery cannot be charged</b>	Charger not connected; charger damaged; battery damaged; temperature too low	Check connections; replace charger; replace battery; move to indoor charging
<b>Abnormal noise from wheel or motor</b>	Loose spokes; damaged rim; motor cable issue	Tighten or replace spokes; repair rim; inspect motor cables

## 8.2 Fault Indicator Descriptions

Indicator	Fault Indicator	Description / Solution
	<b>Low Temperature Fault</b>	Indicates a situation where the ambient temperature is below <b>14°F (-10°C)</b> . At this temperature, the function of the battery will decrease, the capacity will drop, and the battery will become completely unusable at <b>-4°F (-20°C)</b> .
	<b>High Temperature Fault</b>	Power off the device and allow it to cool down for <b>30 minutes</b> before restarting.
	<b>Motor Fault</b>	Restart the e-bike to attempt recovery. If the fault persists, return the bike for <b>mid-drive motor service</b> .

## Indicator

## Fault Indicator

## Description / Solution



### Brake Lever Fault

Release the brake lever and restart the system. If the fault persists, return the bike for **control module service**.



### Throttle Fault

Release the throttle and restart the system. If the fault persists, return the bike for **control module service**.



### Torque Sensor Fault

Stop pedaling and allow the system to shut down completely. Restart the e-bike. If the fault persists, return the bike for **mid-drive motor service**.

## Indicator

## Fault Indicator

## Description / Solution



### Battery Abnormality

Power off the e-bike and allow it to rest for **30 minutes**, then restart. If the fault persists, return the **bike** for factory service of the battery.



### Charging Abnormality

Unplug and reconnect the charger to the bike, ensuring proper contact. Ensure the charging environment remains within **32°F–104°F (0°C–40°C)**. If the fault persists, return the **charger** for factory service.



### Communication Fault

Inspect all wiring harnesses and connector terminals to ensure proper connection, no damage, and secure contact.

### 8.3 App Self-Diagnostic Function

Within the app, navigate to “**Vehicle Diagnostics**” to view detailed fault information and perform preliminary troubleshooting.

This feature helps identify potential issues and provides initial guidance before contacting customer support or service personnel.

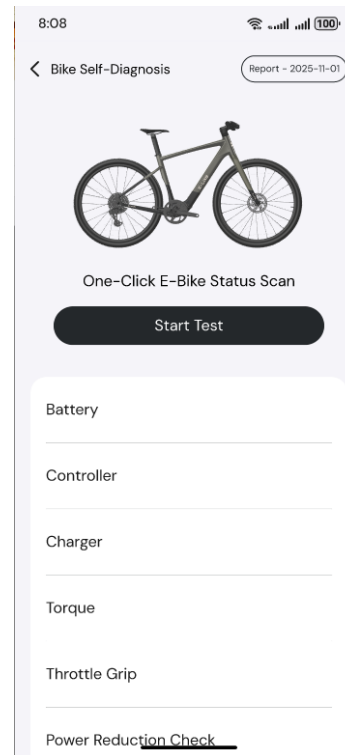

## 8.4 Mobile App Troubleshooting

If you experience issues while using the mobile application, refer to the table below. If the issue cannot be resolved, close the application and restart both the bicycle and your mobile device.

<b>Symptom</b>	<b>Possible Cause</b>	<b>Solution</b>
<b>Unable to connect to the e-bike</b>	Bluetooth is disabled; bicycle is powered off; app not running correctly	Enable Bluetooth on your mobile device; ensure the bicycle is powered on; close and restart the app and try again
<b>Ride data is not saved</b>	Location permissions not enabled; unstable network connection	Ensure the app has location permissions enabled; maintain a network connection while riding

**Images or ride data not displayed correctly**

App cache issue or software error

Clear the app cache or uninstall and reinstall the application

**App cannot detect the bicycle**

Another Bluetooth device is connected; distance too far

Move closer to the bicycle; disconnect other Bluetooth devices; restart the bicycle and app

**App functions are unavailable**

App not updated; unsupported device or OS version

Update the app to the latest version; verify device and operating system compatibility

**NOTICE:** The mobile application can connect to **only one Bluetooth device at a time**. Loss of app connection does not affect basic bicycle operation using the display and controls.

## 9. MAINTENANCE

Proper maintenance is essential for safe operation and long-term performance of the X-Lab electric bicycle. Failure to maintain the bicycle properly may result in component failure, loss of control, or injury.

**NOTICE:** Always power off the bicycle and remove the battery before performing cleaning or maintenance.

### **IMPORTANT**

If you are unfamiliar with maintenance procedures or if the bicycle requires adjustment, consult a qualified bicycle technician.

#### 9.1 Recommended Service Intervals

The service intervals listed below are provided **as general guidelines only**. Actual wear rates and service needs may vary depending on riding conditions, usage frequency, terrain, and riding style.

We generally recommend inspecting, servicing, and replacing components according to the **time or mileage intervals** shown below, whichever occurs first.

<b>Interval</b>	<b>Task</b>	<b>Rider Action</b>	<b>Service Recommendation</b>
<b>Before each ride</b>	Visual safety inspection	Check for loose components, visible damage, abnormal brake lever feel, and unusual noises.	Do not ride if any issue is detected.
<b>Weekly</b>	General cleaning	Clean bicycle with a soft cloth and mild soap. Dry thoroughly after cleaning.	Avoid high-pressure water and solvents.
<b>Monthly</b>	Drivetrain condition	Inspect chain and drivetrain components for dirt, wear, or abnormal operation.	Lubricate and service as needed by a qualified technician if issues are found.

<b>Interval</b>	<b>Task</b>	<b>Rider Action</b>	<b>Service Recommendation</b>
<b>Monthly</b>	Brake system condition	Inspect brake pads and rotors for visible wear or contamination.	Have brakes serviced by a qualified bicycle technician if performance is reduced.
<b>Monthly</b>	Fastener check	Check for visibly loose fasteners.	Torque verification by a technician if looseness is observed.
<b>Every 3–6 months</b>	Electrical system check	Inspect cables and connectors for visible damage.	Electrical service must be performed by authorized personnel only.

<b>Interval</b>	<b>Task</b>	<b>Rider Action</b>	<b>Service Recommendation</b>
<b>Every 3–6 months</b>	Battery condition	Inspect battery for damage, swelling, or abnormal behavior.	Replace or service battery if abnormalities are observed.
<b>Before long-term storage</b>	Storage preparation	Clean bicycle and store in a dry, temperature-controlled location.	Follow battery storage guidance in Section 5.
<b>After a crash</b>	Safety inspection	Do not ride the bicycle.	Full inspection by a qualified bicycle technician is required.

## **10. CERTIFICATION AND COMPLIANCE INFORMATION**

This section provides regulatory and compliance information applicable to this device and its wireless communication features.

### **10.1 Federal Communications Commission (FCC) Compliance**

FCC ID: **2BTR6-T901**

This device complies with part 15 of the FCC Rules. Operation is subject to the condition that this device does not cause harmful interference (1) this device may not cause harmful interference, and (2) this device must accept any interference received, including interference that may cause undesired operation.

Changes or modifications not expressly approved by the party responsible for compliance could void the user's authority to operate the equipment.

#### **NOTICE:**

This equipment has been tested and found to comply with the limits for a Class B digital device, pursuant to Part 15 of the FCC Rules. These limits are designed to provide reasonable protection against harmful interference in a residential installation.

This equipment generates, uses and can radiate radio frequency energy and, if not installed and used in accordance with the instructions, may cause harmful interference to radio communications. However, there is no guarantee that interference will not occur in a particular installation.

If this equipment does cause harmful interference to radio or television reception, which can be determined by turning the equipment off and on, the user is encouraged to try to correct the interference by one or more of the following measures:

- Reorient or relocate the receiving antenna.
- Increase the separation between the equipment and receiver.
- Connect the equipment into an outlet on a circuit different from that to which the receiver is connected.
- Consult the dealer or an experienced radio/TV technician for help.

**To maintain compliance with FCC's RF Exposure guidelines, this equipment should be installed and operated with a minimum distance of 8 in (20 cm) between the radiator and the human body. Use only the supplied antenna.**

## 10.2 Apple Find My Network Compliance

Use of the Works with Apple badge means that a product has been designed to work specifically with the technology identified in the badge and has been certified by the product manufacturer to meet Apple Find My network product specifications and requirements. Apple is not responsible for the operation of this device or use of this product or its compliance with safety and regulatory standards.

To use the Find My app to locate this item, the latest version of iOS®, iPad OS®, or mac OS® is recommended.

The Find Items app on Apple Watch® requires the latest version of watch OS®. Apple Find My, Apple Watch, Find My, iPhone, iPad, iPad OS, iPod touch, Mac, mac OS and watch OS are trademarks of Apple Inc. iOS is a trademark of Cisco and is used under license.



### **10.3 Learn More Instructions**

- 1** Locate the control buttons on the XDS e-bike and press and hold the power button to ensure the system is powered on.
- 2** Quickly press both the “+” and “-” buttons three times, then press and hold the “+” and “-” buttons simultaneously for two seconds.
- 3** Three confirmation beeps will sound to indicate the action has been completed.

### **10.4 How to Disable**

- 1** Locate the control buttons on the XDS e-bike and press and hold the power button to ensure the system is powered on.
- 2** Quickly press both the “+” and “-” buttons twice, then press and hold the “+” and “-” buttons simultaneously for two seconds.
- 3** Three confirmation beeps will sound to indicate the action has been completed.

## 11. WARRANTY, SUPPORT, AND CONTACT INFORMATION

This section provides general information regarding warranty coverage, customer support, and contact resources for your X-Lab electric bicycle.

### 11.1 Warranty Overview

X-Lab electric bicycles are covered by a **Limited Warranty** against defects in materials and workmanship, subject to the terms and conditions established by X-Lab.

Warranty coverage:

- Applies only to the **original purchaser**.
- Covers manufacturing defects under normal use.
- Does not cover normal wear and tear or damage caused by misuse, improper assembly, improper maintenance, accidents, or unauthorized modifications.

Warranty terms, coverage periods, and exclusions may vary by product and are subject to change.

For the most current and complete warranty information, visit <https://www.xds.co/warranty>.

## 11.2 Warranty Limitations and Exclusions

The Limited Warranty does not cover:

- Normal wear items such as tires, brake pads, chains, cables, and grips.
- Damage resulting from improper assembly or failure to follow this manual.
- Damage caused by accidents, crashes, misuse, neglect, or commercial use.
- Unauthorized modifications or installation of non-approved parts or accessories.
- Damage resulting from use outside recommended operating conditions.

Failure to follow the instructions and warnings in this manual may void warranty coverage.

## 11.3 Customer Support

If you have questions regarding assembly, operation, maintenance, troubleshooting, or warranty coverage, contact X-Lab Customer Support at [support@xds.co](mailto:support@xds.co).

Before contacting support, have the following information available:

- Bicycle model
- Serial number (SN)
- Proof of purchase
- A brief description of the issue

Providing complete information will help expedite assistance.

## 11.4 Service and Repairs

For safety and reliability:

- Repairs should be performed by a **qualified bicycle technician**.
- Electrical system service must be performed by **authorized service personnel only**.

### **WARNING**

Improper repair or modification may result in unsafe riding conditions and could lead to serious injury.

## 11.5 Contact Information

For customer support, warranty service, or additional product information, visit the official X-Lab website or contact X-Lab through authorized service channels.

Contact details and service resources may be updated periodically. Refer to the official website for the most current information.

## **11.6 Retention of Documentation**

Retain this manual, proof of purchase, and all related documentation for future reference.

If the bicycle is sold or transferred, provide this manual to the subsequent owner.

## **11.7 Regulatory and Legal Notices**

This electric bicycle is intended for use in accordance with applicable federal, state, and local laws and regulations. Laws governing electric bicycles vary by jurisdiction, and the rider is responsible for understanding and complying with all applicable requirements.

Do not modify, alter, or tamper with the bicycle, motor system, battery, controller, software, or electrical components. Unauthorized modifications may compromise safety, void warranty coverage, and result in non-compliant operation.

The contents of this manual, including product features and mobile application functionality, are subject to updates and revisions. Refer to the official X-Lab website for the most current information.

X-LAB

SHENZHEN XIDESHENG BICYCLE CO.LTD

---

[www.xds.co](http://www.xds.co) | [hello@xds.co](mailto:hello@xds.co)